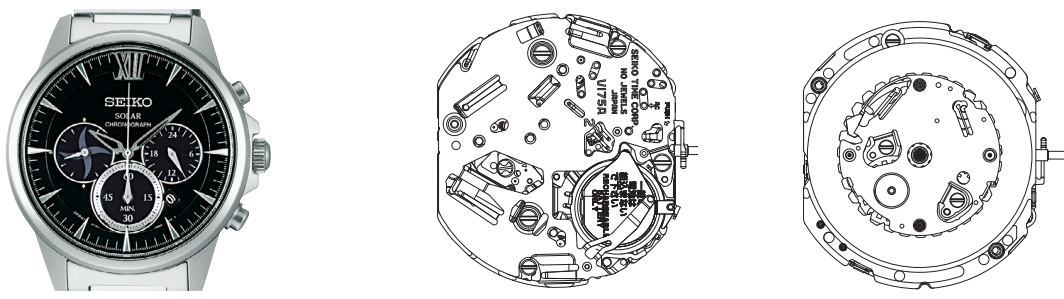

PARTS LIST/TECHNICAL GUIDE

ANALOGUE SOLAR Cal. V175A

[SPECIFICATIONS]

Cal. No.		V175A
Item		
 <p>3 hands (hour, minute and small second hands), 24-hour indicator</p> <p>Diameter: Outside 27.6 mm Casing 27.0 mm Height: 4.4 mm</p>		
Motion of the second hand		One-second intervals
Driving system		Stepping motor 3 pieces
Additional function		<ul style="list-style-type: none"> • Energy depletion forewarning function (The second hand moves at two-second intervals.) • Overcharge prevention function • Electronic circuit reset function • Second hand stop function • Date calendar • Instant setting device for date calendar • System reset function • Stopwatch function..... 60-minute stopwatch in 1/5-second increments (Auto stop measuring at 60 minutes) Accumulated elapsed time measurement Split time measurement Stopwatch hand position adjustment
Crown operation	Normal position	Stopwatch
	1st click position	Date setting (clockwise), Stopwatch
	2nd click position	Time setting, System reset, Setting "0" of stopwatch hand
Loss/Gain		Monthly rate: less than 15 seconds (worn on the wrist at temperature range between 5 to 35 degrees Centigrade)
Regulation system		Nil
Gate time for rate measurement		Use 10-second gate
Current consumption		Movement: less than 0.95 μ A Circuit block: less than 0.30 μ A
Coil resistance		4002 541 1.90 - 2.30 k Ω (COIL BLOCK) (COIL BLOCK FOR CHRONOGRAPH 1/5-SECOND) 4002 542 1.75 - 2.15 k Ω (COIL BLOCK FOR CHRONOGRAPH MINUTE)
Power supply	Power generator	Solar power generation system
	Rechargeable battery	MT920 Manganese titanium lithium rechargeable battery
	Operating voltage range	0.90V - 2.10V
	Power reserve	From full charge to stoppage: Approximately 6 months
Number of jewels		Nil

SEIKO WATCH CORPORATION

FEATURES

Cal. V175A is an analogue chronograph watch with a solar power generation system. The basic movement structure is similar to Cal. V172A/V174A, and the knowledge and technique you have gained in handling the Cal. V172A/V174A watches will come in handy when you repair Cal. V175A. The differences from Cal. V172A/V174A are as follows:

- Alarm function is deleted.
- Minute CG indicator position is changed from 12h position to 6h position
- 24 hour indicator is added at 3h position
- Date calendar position is changed from 4h position to 4.5h position
- Solar power generation system

The watch operates while charging electricity by converting light received on the dial to electrical energy. It lasts for 6 months after full charge.

- Energy depletion forewarning function

When the energy stored in the rechargeable battery is reduced to an extremely low level, the second hand starts moving at 2-second intervals instead of the normal 1-second intervals.

- Guideline of charging time

Environment/Light source	Illumination (lux)	Time required for full charge	Time required for steady operation	Time to charge 1 day of power
General offices/ Fluorescent Light	700	-	60 hours	150 minutes
30W 20cm/Fluorescent light	3,000	110 hours	13 hours	33 minutes
30W 3cm/ Fluorescent light	10,000	30 hours	3.5 hours	9 minutes
Cloudy weather/Sunlight	10,000	30 hours	3.5 hours	9 minutes
Fair weather/Sunlight	100,000	5 hours	0.6 hours	2 minutes

The above table provides only a general guideline.

It is recommended that the watch be charged for as long as the charging time according to the column "Time required for steady operation" in this table in order to assure the stable movement of the watch.

- Caution for charging

When charging the watch, do not place it too close to a photo flash light, spotlight, incandescent light or other light sources as the watch temperature will become extremely high, causing damage to the parts inside the watch.

When exposing the watch to sunlight to charge it, do not leave it on the dashboard of a car, etc. for a long time, as the watch temperature becomes extremely high.

While charging the watch, make sure the watch temperature does not exceed 60 °C.

PARTS LIST

Cal. V175A

Order of disassembly: ① → ⑥②
 Order of assembly: ⑥② → ①
 Lubricating:
 Types of oil Oil quantity
 ● ▲ AO-3 ○ ▲ Normal quantity
 ● ▲ AO-2

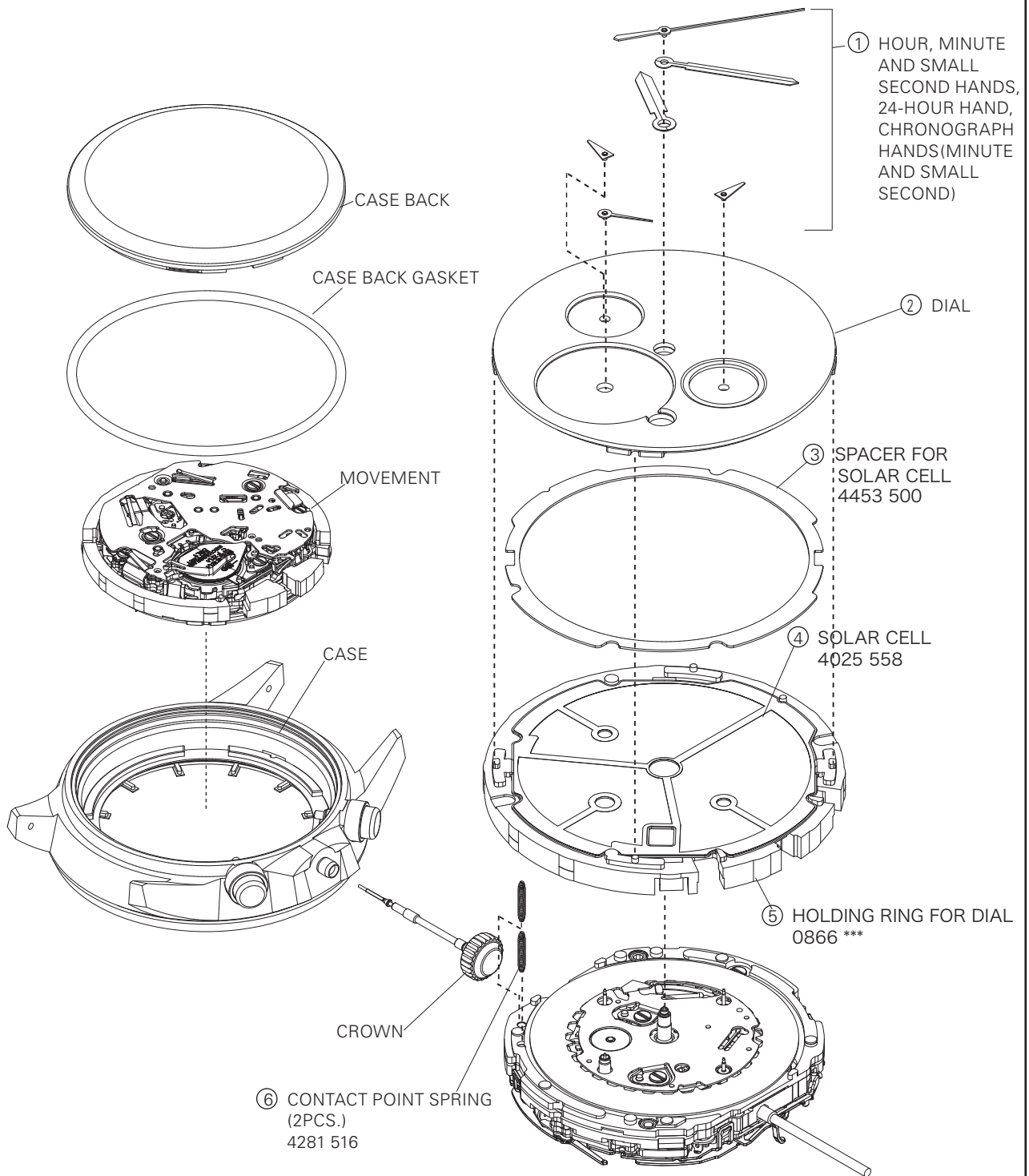

PARTS LIST

Cal. V175A

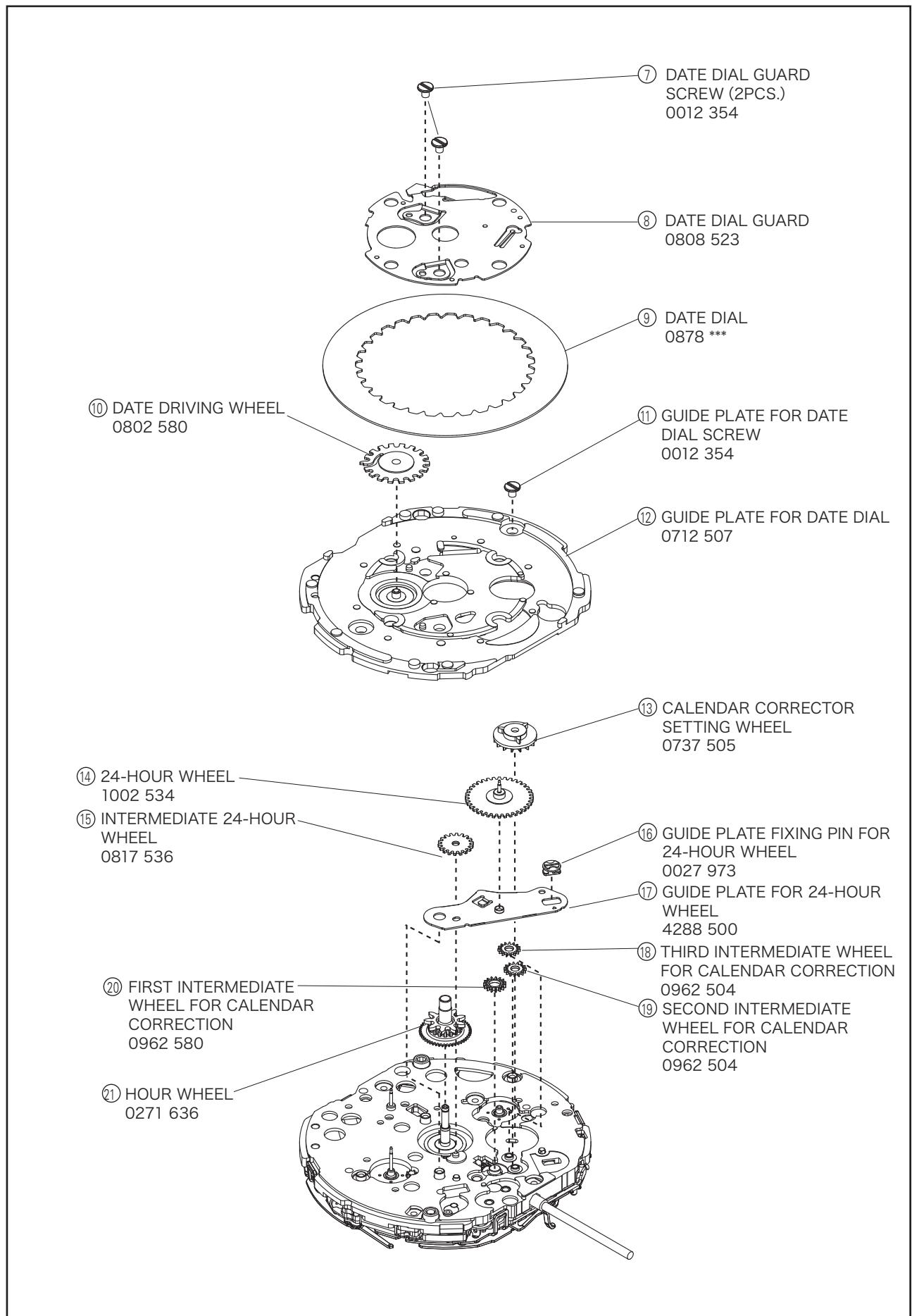

PARTS LIST

Cal. V175A

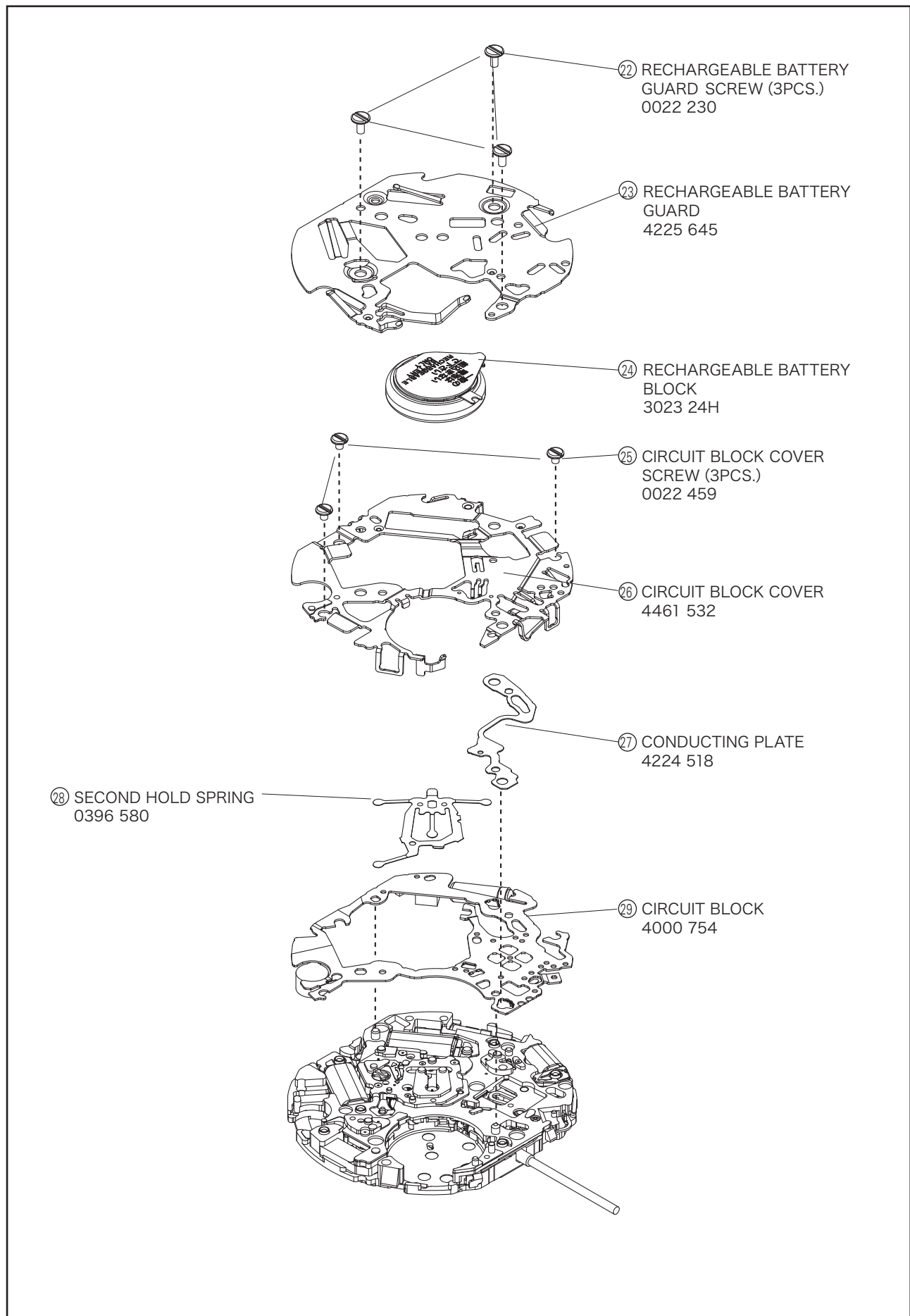

PARTS LIST

Cal. V175A

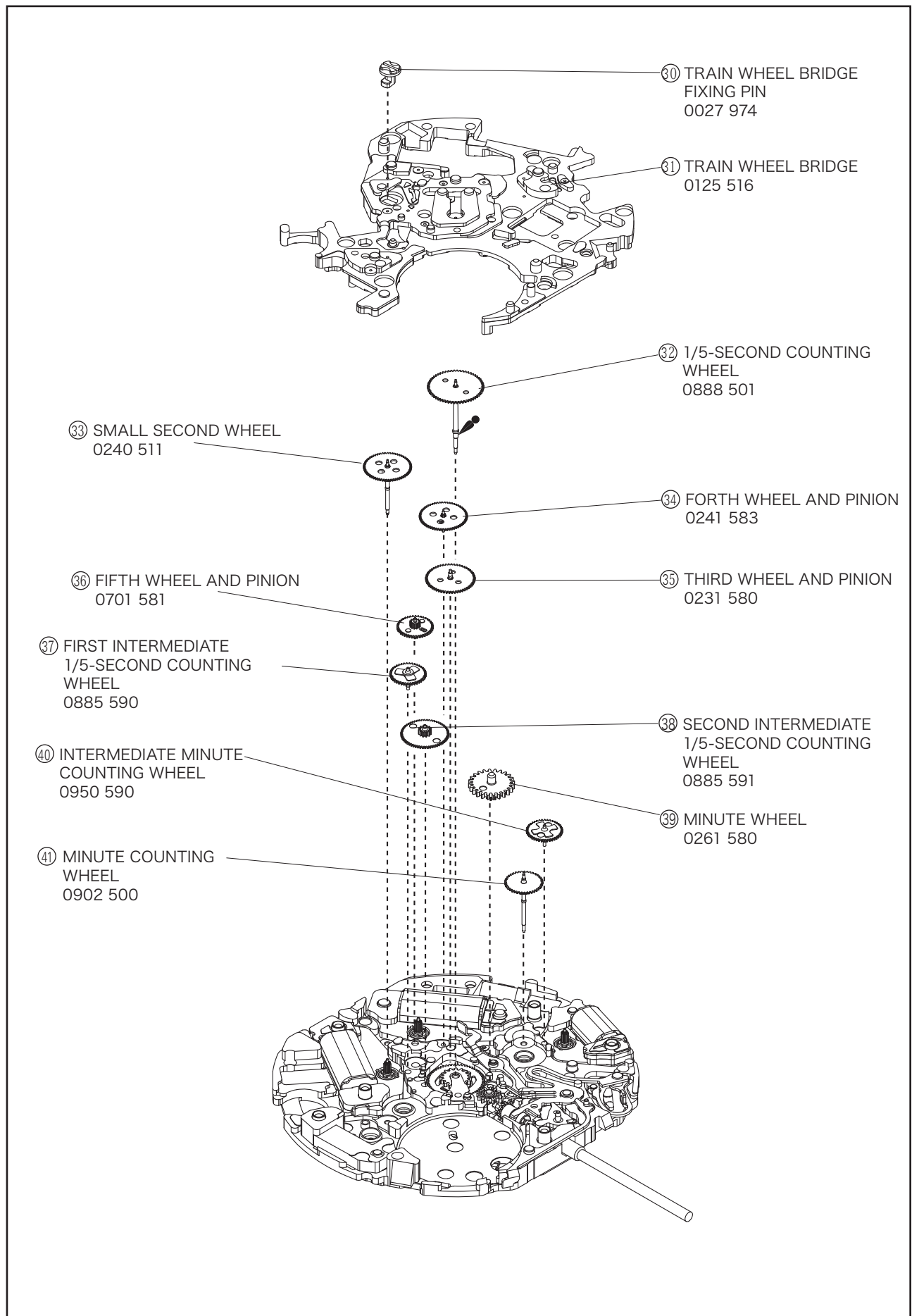

PARTS LIST

Cal. V175A

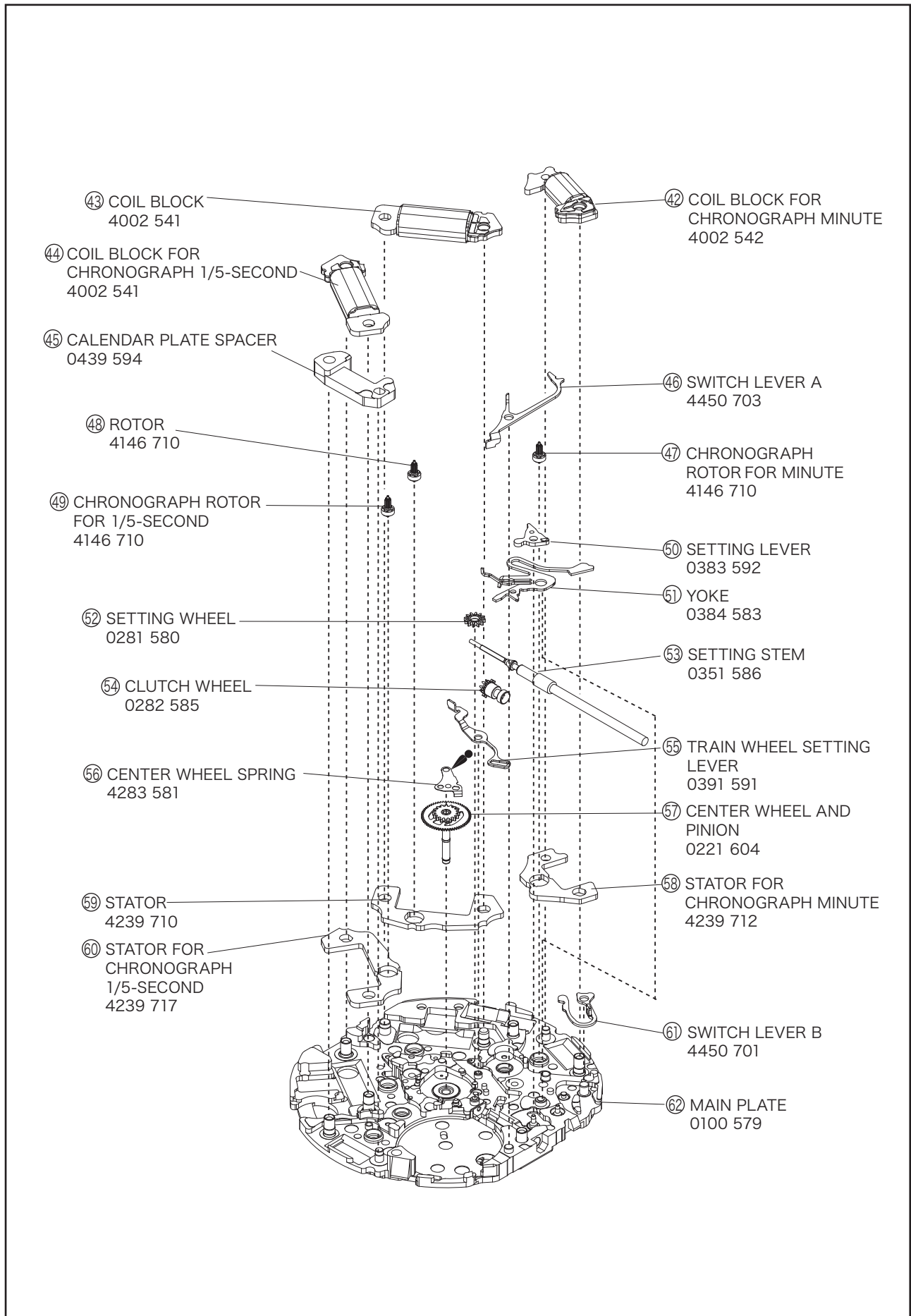

PARTS LIST

Cal. V175A

● **How to find the correct parts, if not determined by 4 digit caliber number**

Following parts are determined based on the design of watches, such as hands height, dial color, and design of cases. Please refer to the SEIKO WATCH PARTS CATALOGUE in order to choose the corresponding parts.

- ⑤ HOLDING RING FOR DIAL 0866 ***
- ⑨ DATE DIAL 0878 ***
- ⑤③ WINDING STEM 0351 586

● **Other parts to pay attention to:**

- ①⑥ GUIDE PLATE FIXING PIN 0027 973
- ③① TRAIN WHEEL BRIDGE FIXING PIN 0027 974

Refer to the following figures.

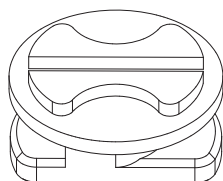

①⑥ GUIDE PLATE FIXING PIN
0027 973

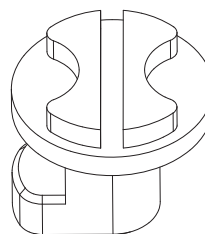

③① TRAIN WHEEL BRIDGE
FIXING PIN
0027 974

- ⑨ SOLAR CELL 4025 558

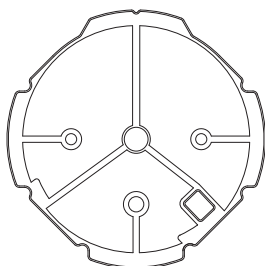

Cal.	Parts Number
V172A	4025 556
V174A	4025 557
V175A	4025 558

Note: Solar cell differs according to each caliber.

- ②⑨ CIRCUIT BLOCK 4000 754

There is a hole on a CIRCUIT BLOCK for V175A in order to distinguish from others.

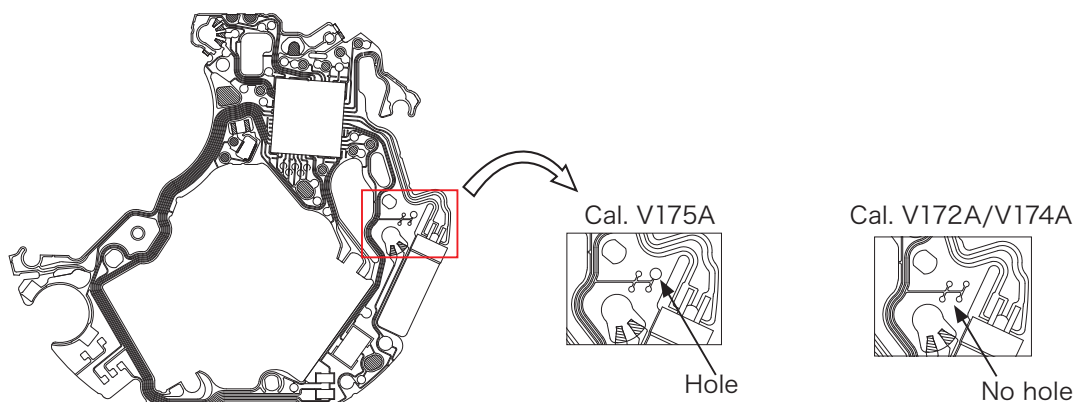

PARTS LIST

Cal. V175A

- **Tools and consumables required for disassembling/reassembling**

- **Movement holder**

UNIVERSAL MOVEMENT HOLDER (S-682)

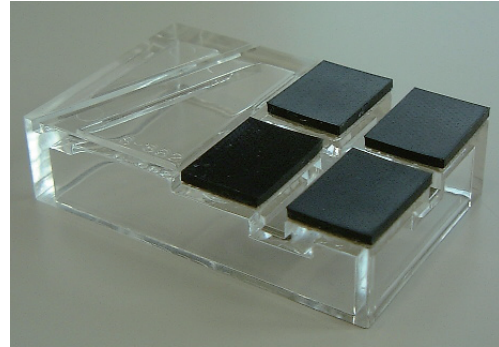

- **Watch oils**

SEIKO watch oils (AO-3 and AO-2) and SEIKO watch grease S-6

AO-3



AO-2



S-6



REMARKS ON DISASSEMBLING AND REASSEMBLING

① HANDS

• How to install

- * Match the polarity of the ROTORS for STOPWATCH and ALARM, and then install the hands.

Check that the voltage of rechargeable battery exceeds 1.2 V and the watch is working.

- * Crown position: normal position.

Short-circuit by touching the AC pattern and the rechargeable battery guard with tweezers (refer to the Fig. 1).

In order to match the polarity of the ROTORS, short-circuit by touching the pattern A and the rechargeable battery guard with tweezers (refer to the Fig. 2).

Install the CHRONOGRAPH minute hand at "0" position.

Pull out the crown to the second position, then turn it clockwise in order to change the calendar.

Install the small second hand, the 24-hour hand, the hour hand, the minute hand and the CHRONOGRAPH second hand at "0" position.

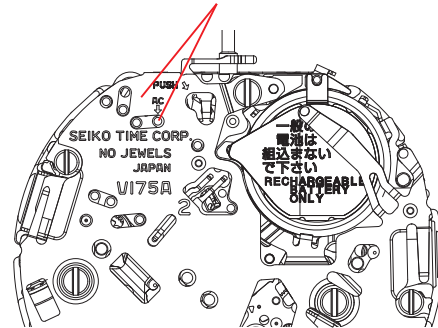

Fig. 1

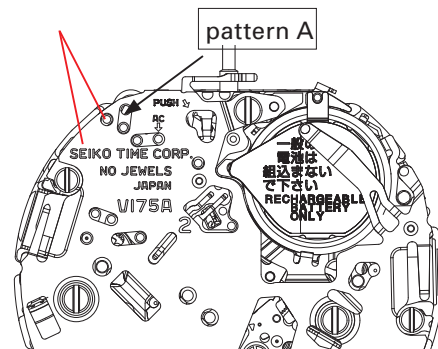
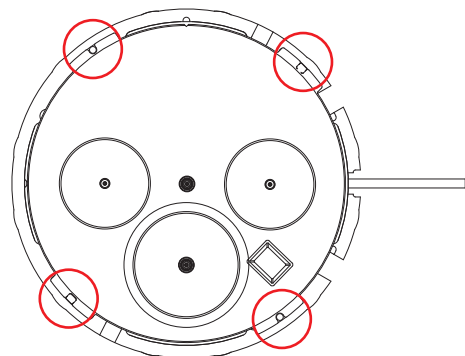

Fig. 2

② DIAL

• How to install

Set the notched portions of the dial to the guide posts (4 posts) of the HOLDING RING FOR DIAL, and check that the dial is fixed in position.



③ SPACER FOR SOLAR CELL

• How to install

Set the notched portions of the SPACER FOR SOLAR CELL to the guide posts (5 posts) of the HOLDING RING FOR DIAL, and check that the dial is fixed in position.

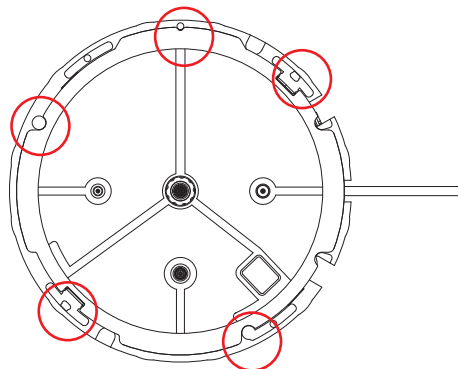

REMARKS ON DISASSEMBLING AND REASSEMBLING THE MOVEMENT

④ SOLAR CELL

⑤ HOLDING RING FOR DIAL

* It is not necessary to separate the SOLAR CELL and the HOLDING RING FOR DIAL except in the case that a part needs to be replaced.

• Disassembling and Reassembling of HOLDING RING FOR DIAL

<Disassembling>

1. The HOLDING RING FOR DIAL is fixed to the movement by the hooking portion at 4 o'clock and 11 o'clock positions.
2. Insert the tip of a screwdriver into the gap between the hooking portion and main plate to release the hooking portion from the main plate as shown with the arrow mark in the illustration.

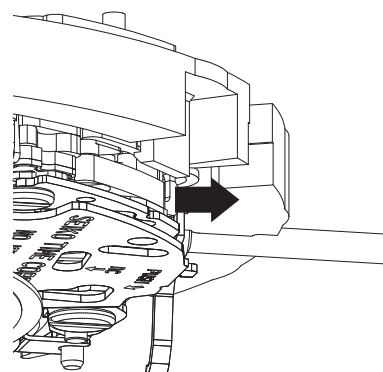

<Reassembling>

1. Set the 2 hooking portions to 4 o'clock and 11 o'clock positions as shown in the illustration.
2. Gently push the hooking portions of HOLDING RING FOR DIAL so that they catch the main plate securely.

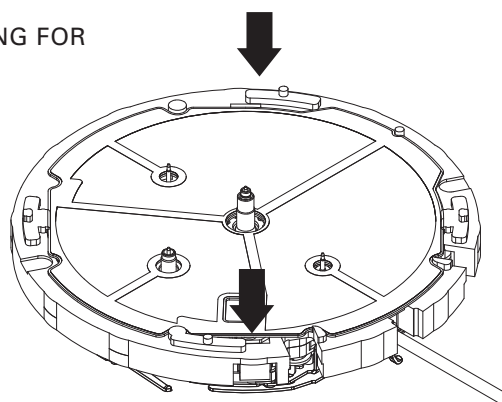

- **Disassembling and Reassembling of SOLAR CELL**

- * **Do not apply excessive force to the SOLAR CELL.**

<Disassembling>

As there are 2 connection parts of the HOLDING RING FOR DIAL, release them side by side.

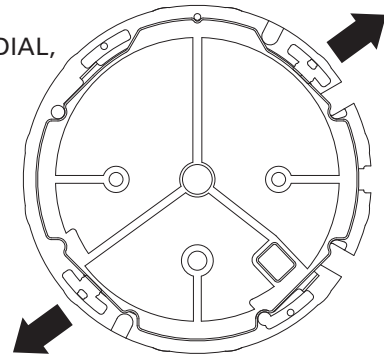

<Assembling>

Set the SOLAR CELL to 3 guide posts, and assemble it to the HOLDING RING FOR DIAL by expanding at the hooking portion as shown in the illustration.

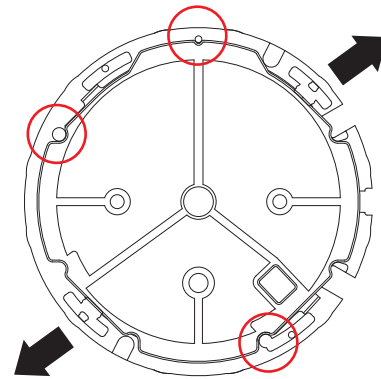

⑧ **DATE DIAL GUARD**

- **Lubrication**

Lubricate the DATE JUMPER and the tip of the DATE INDICATOR.

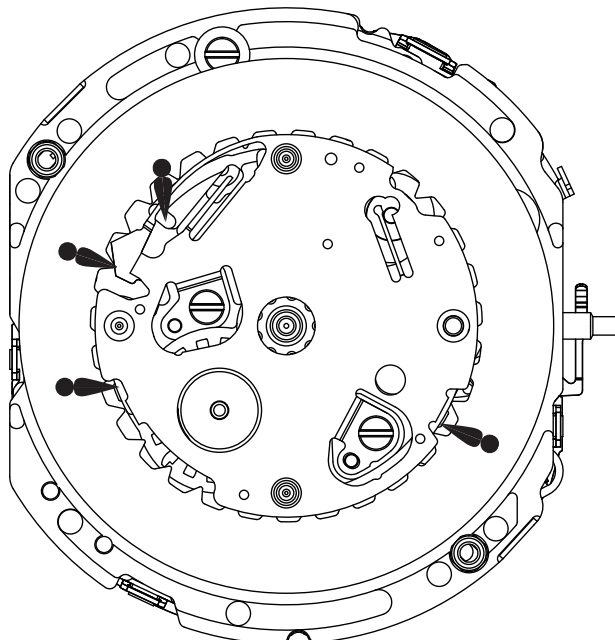

23 RECHARGEABLE BATTERY GUARD

• **Assembling**

Set the RECHARGEABLE BATTERY GUARD to the guide posts (2 posts), and then tighten the rechargeable battery guard screws (3 pcs.).

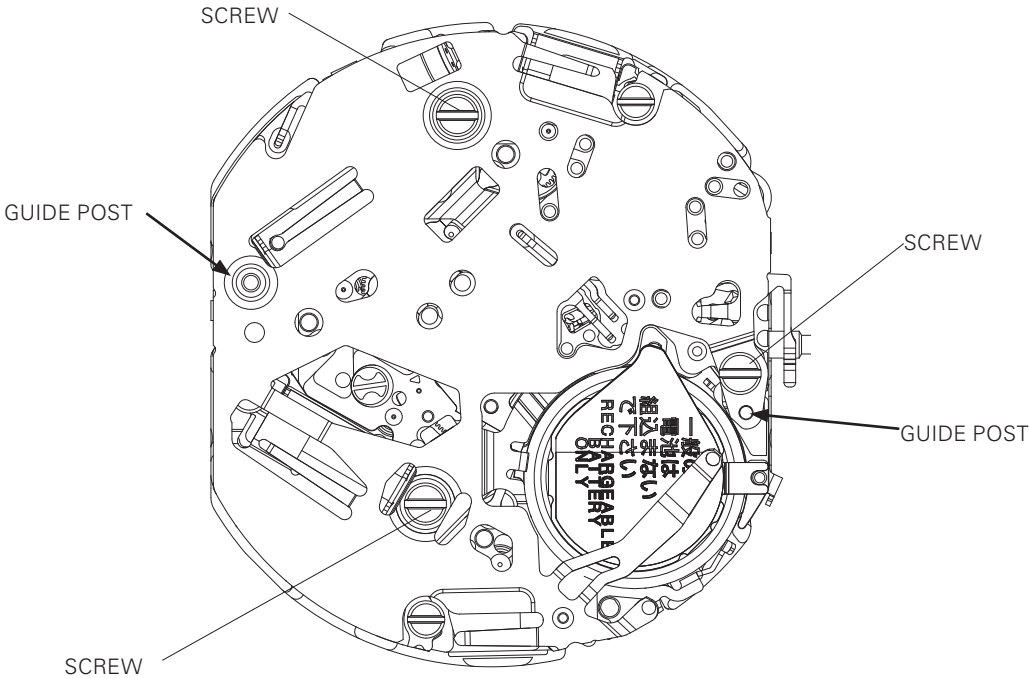

②④ RECHARGEABLE BATTERY BLOCK

- **Assembling**

Set the notched portion of the RECHARGEABLE BATTERY BLOCK to the guide post, and check that the hooking portion of the RECHARGEABLE BATTERY BLOCK touches the (-) input terminal of the CIRCUIT BLOCK.

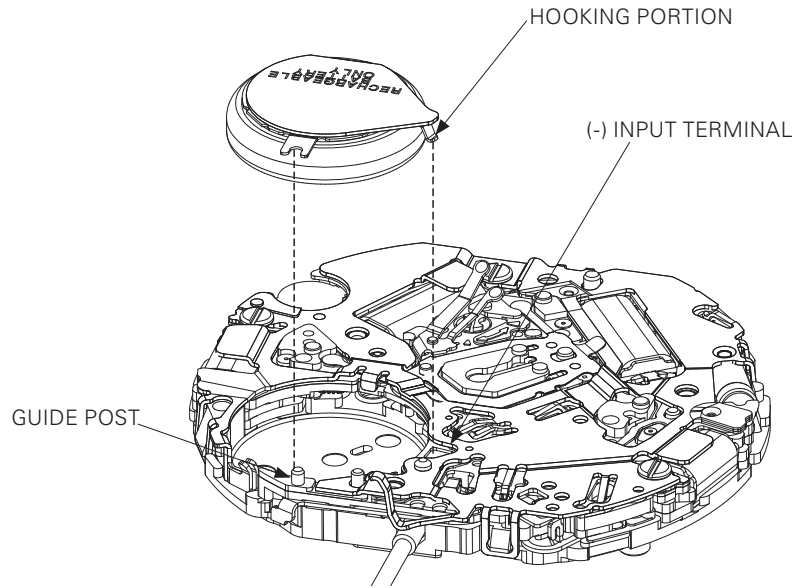

26 CIRCUI T BLOCK COVER

- **Disassembling**

1. Loosen the 3 CIRCUI T BLOCK COVER SCREWS.
2. Release the 4 hooking portions of the CIRCUI T BLOCK COVER (indicated by the arrows in the illustration below.)

- **Assembling**

1. Have the four hooking portions of the CIRCUI T BLOCK COVER (indicated by the arrows in the illustration below) catch the movement securely. In doing so, check if the circuit block is set properly to guide posts "a," "b," and "c," and reset it in position if necessary.
2. Tighten the 3 CIRCUI T BLOCK COVER SCREWS. When tightening the screws, take care not to cut the coil.

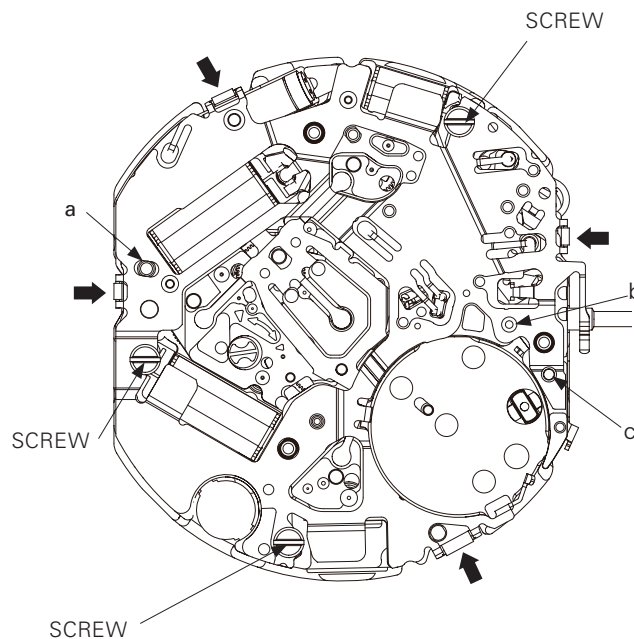

27 CONDUCTING PLATE

- **Assembling**

Put the CONDUCTING PLATE on the CIRCUI T BLOCK as shown in the illustration, and secure it with the 2 guide posts.

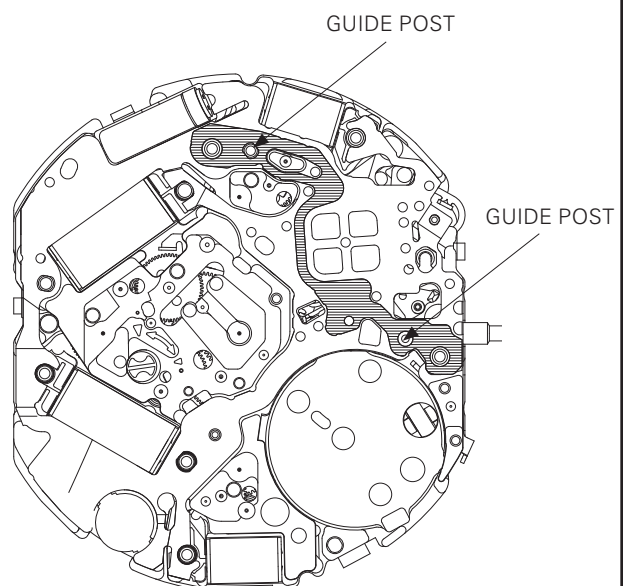

②⑧ SECOND HOLD SPRING

- **Setting place**

Slide a part of the SECOND HOLD SPRING under the TRAIN WHEEL BRIDGE.

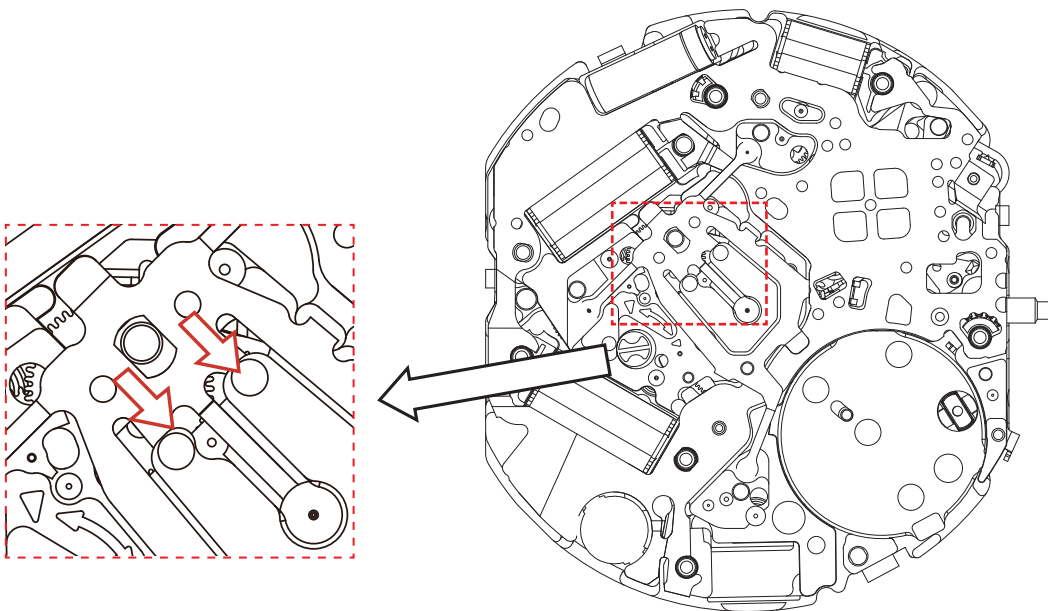

②⑨ CIRCUIT BLOCK

- **Disassembling**

Take care not to damage the CIRCUIT BLOCK, remove it from the posts of the TRAIN WHEEL BRIDGE and the screw pins of the MAIN PLATE (refer to a, b, c, d and e in the illustration).

- **Reassembling**

Set the guide holes of the CIRCUIT BLOCK (refer to a, b, c, d and e in the illustration) to the posts of the TRAIN WHEEL BRIDGE and the screw pins of the MAIN PLATE.

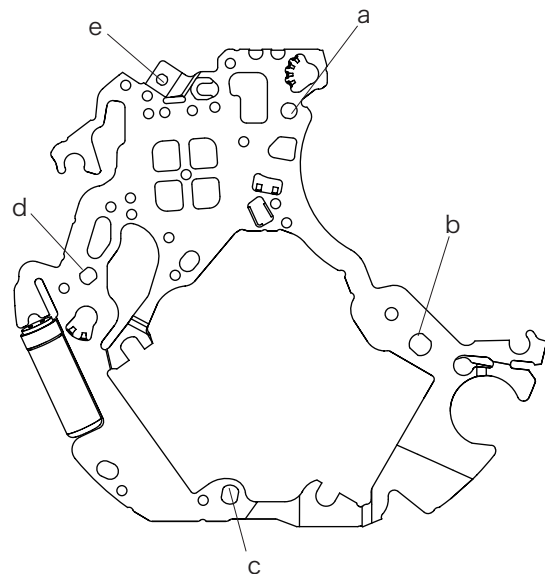

③⑩ TRAIN WHEEL BRIDGE FIXING PIN

• Disassembling

Turn the TRAIN WHEEL BRIDGE FIXING PIN to the left for 90 degrees, and loosen it.

• Reassembling

Set the TRAIN WHEEL BRIDGE FIXING PIN as shown in the illustration, and fasten it by turning it 90 degrees to the right. (Refer to the Fig. 1.)

<Lubrication>

After fastening the TRAIN WHEEL BRIDGE FIXING PIN, lubricate the upper part of the pivots of the following parts (refer to the Fig. 2):

- 3 ROTORS: AO-2
- MINUTE WHEEL: AO-3
- SMALL SECOND HAND: AO-3
- MINUTE COUNTING WHEEL: AO-3
- 1/5-SECOND COUNTING WHEEL: AO-3

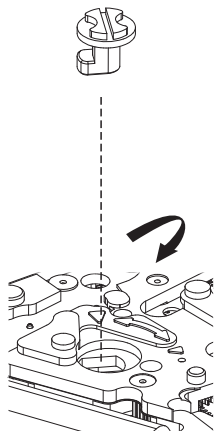

Fig. 1

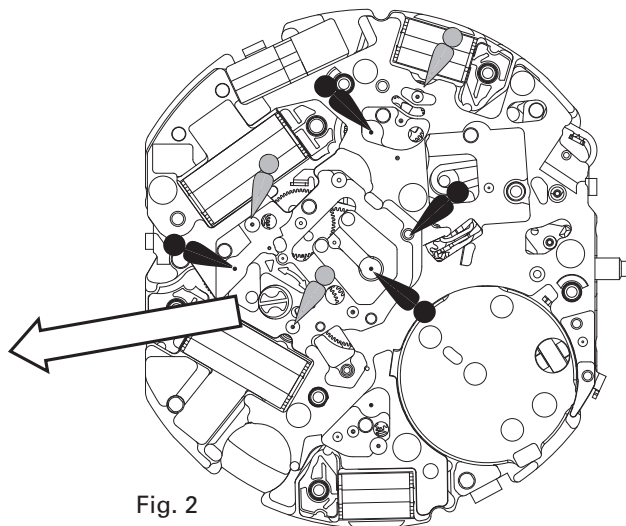
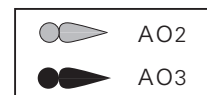

Fig. 2



③⑪ TRAIN WHEEL BRIDGE

• Assembling

1. Check the setting positions of the WHEELS and ROTORS carefully. Be sure to check that lower pivot of rotors are set to the MAIN PLATE properly.
2. Pull out the SETTING STEM to the 1st click position.
3. Install the TRAIN WHEEL BRIDGE without pushing strongly. If the BRIDGE cannot be installed smoothly, recheck the setting position of WHEELS and ROTORS as some parts may be set in the wrong position.

<Setting position>

Refer to the illustration in the next page.

PARTS LIST

Cal. V175A

● How to identify the gear train parts

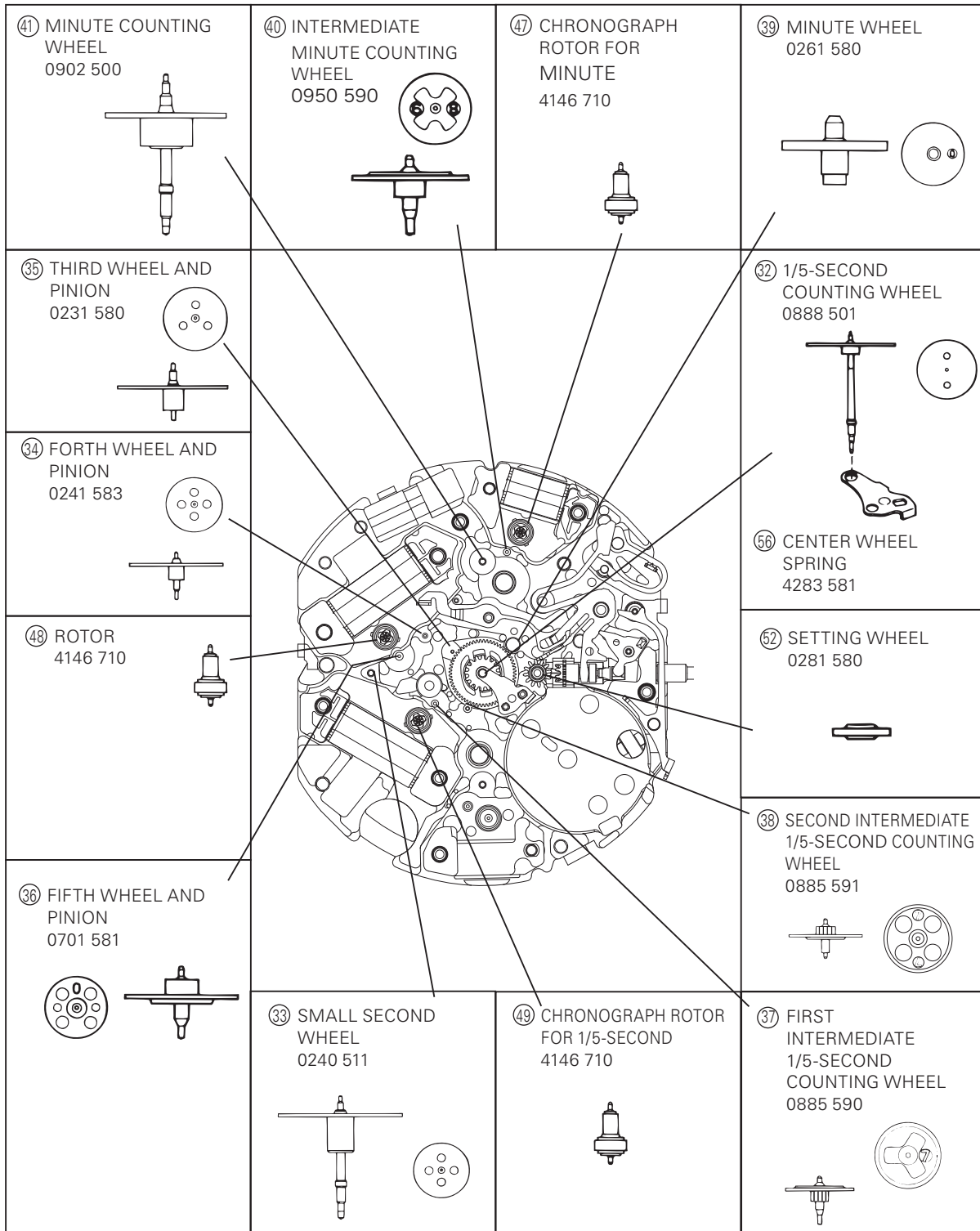

Note ◆ The following ROTORS are the same.

- ROTOR
- CHRONOGRAPH ROTOR FOR MINUTE
- CHRONOGRAPH ROTOR FOR 1/5-SECOND

PARTS LIST

Cal. V175A

● How to lubricate

- ④6 SWITCH LEVER A
- ⑤0 SETTING LEVER
- ⑤1 YOKE
- ⑤5 TRAIN WHEEL SETTING LEVER

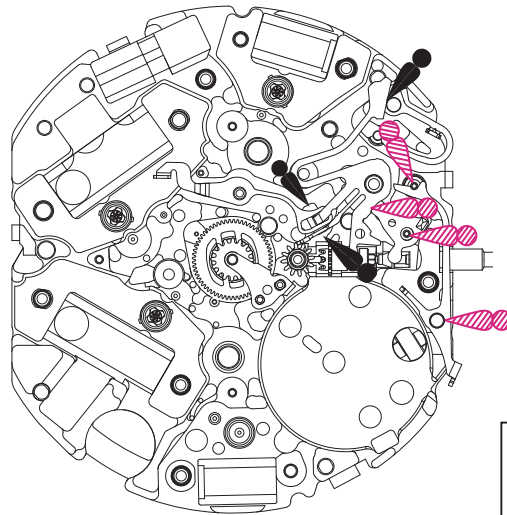

- ⑤3 WINDING STEM

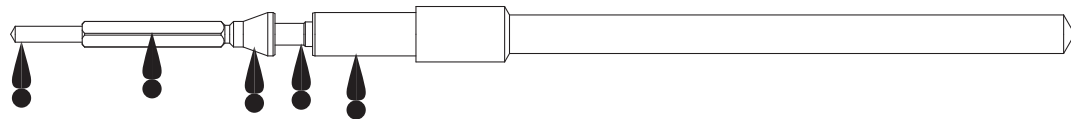

	AO 3
	S-6

- ⑤7 CENTER WHEEL AND PINION

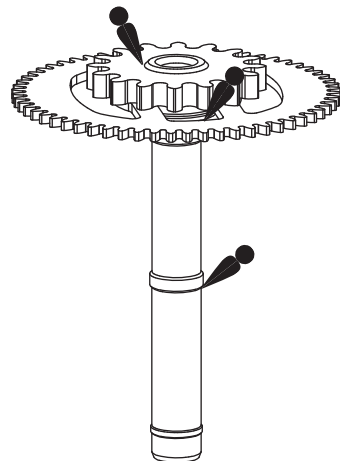

- ⑥2 MAIN PLATE

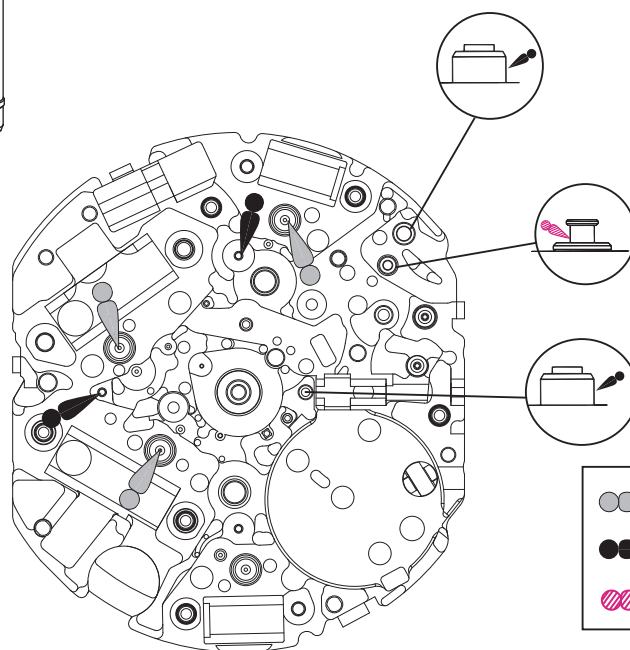

	A02
	A03
	S-6

REMARKS ON INSPECTION AND MEASUREMENT

● CHECKING THE ELECTRICAL CHARACTERISTICS

<Coil resistance>

- ④③ COIL BLOCK (4002 541) between 1.90 and 2.30 kΩ
- ④④ COIL BLOCK FOR CHRONOGRAPH 1/5 SECOND (4002 541) between 1.90 and 2.30 kΩ
- ④② COIL BLOCK FOR CHRONOGRAPH MINUTE (4002 542) between 1.75 and 2.15 kΩ

<How to measure the current consumption for the whole movement>

- 1) Remove ⑤ HOLDING RING FOR DIAL, ④ SOLAR CELL and ②④ RECHARGEABLE BATTERY BLOCK from the movement.
- 2) Set ②③ RECHARGEABLE BATTERY GUARD, and then tighten 3 screws.
- 3) Connect the (-) probe to the (-) input terminal of ④③ COIL BLOCK and the (+) probe to the (+) input terminal of ④③ COIL BLOCK as illustration.
- 4) Touch the AC terminal of the CIRCUIT BLOCK and the switch spring with the tweezers to reset the circuit as illustrated.

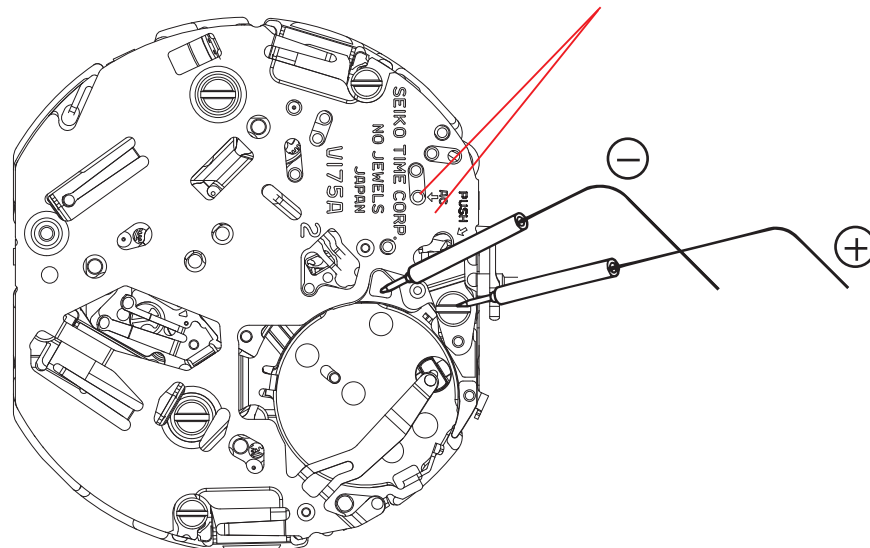

- * When measuring the current consumption using the SEIKO digital multi-tester (S-860), use the range of 40μA of SUPPLY V (=1.55V) & GATE TIME (2S).

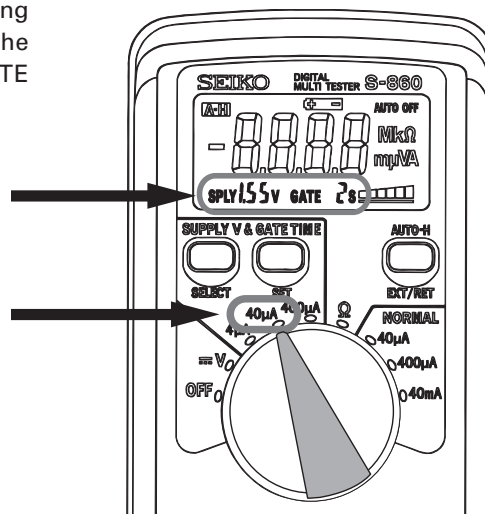

- 5) Wait until a stable measurement becomes available. It usually takes 30 seconds to a few minutes for getting a stable measurement.
- 6) Make sure that the read value is less than 0.95μA.

<How to measure the current consumption for the CIRCUIT BLOCK alone>

1) Connect each probe to the appropriate (-) and (+) input terminal of ②9 CIRCUIT BLOCK (please refer to the "Structure of the CIRCUIT BLOCK" below).

- * When measuring the current consumption using the SEIKO digital multi-tester (S-860), use the range of 40 μ A of SUPPLY V (=1.55V) & GATE TIME (2S).
- * Avoid exposing the CIRCUIT BLOCK to direct light in order to obtain the correct measurement.

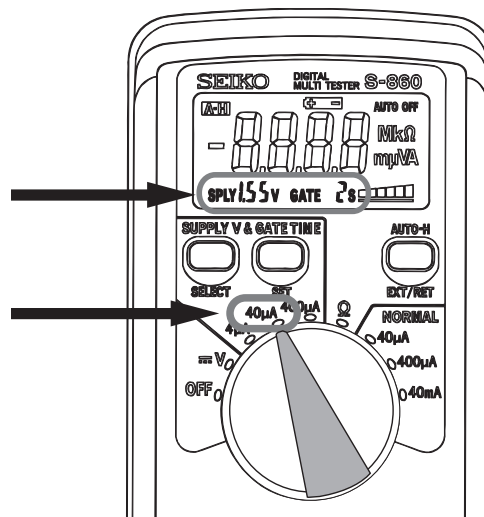

- 2) Wait until a stable measurement becomes available. It usually takes 30 seconds to a few minutes for getting a stable measurement.
- 3) Make sure that the read value is less than 0.30 μ A.

[Structure of the CIRCUIT BLOCK]

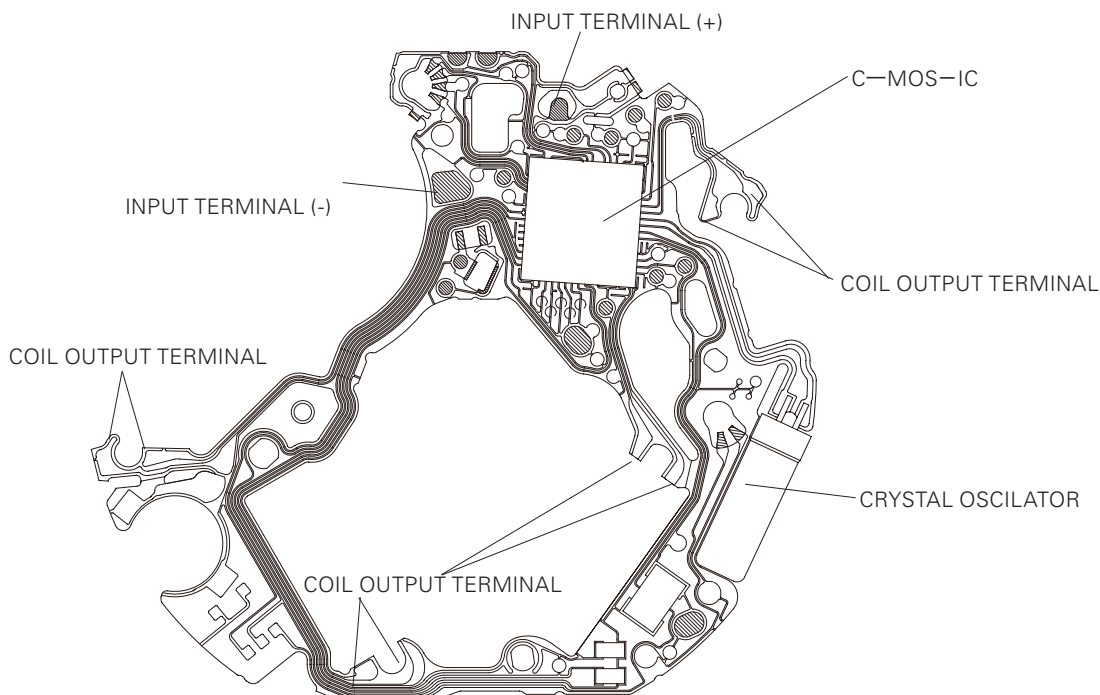

Note:

In case the measurement of the current consumption for a whole movement exceeds the standard value but the measurement for the circuit falls below the standard value, a problem in the gear train mechanism is suspected. Please disassemble and overhaul the movement and measure the current again.

● CHECKING THE SOLAR POWER GENERATION SYSTEM

<How to check the solar power generation with the watch>

- 1) Remove the RECHARGEABLE BATTERY UNIT from the watch.
- 2) Pull out the crown to the 2nd click in order to reset the circuit.
- 3) Connect the (-) probe and (+) probe as illustrated.

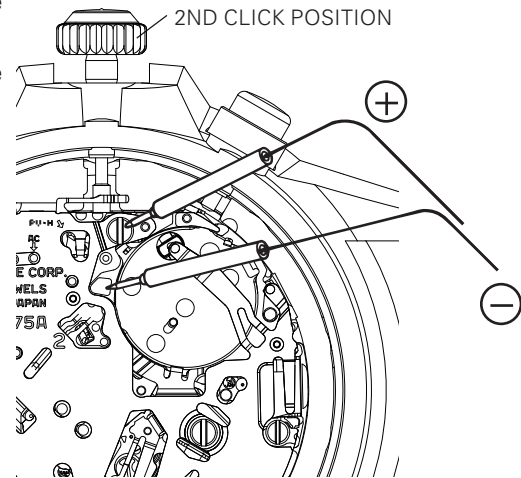

- * When measuring the voltage using the SEIKO digital multi-tester (S-860), use the range of V.

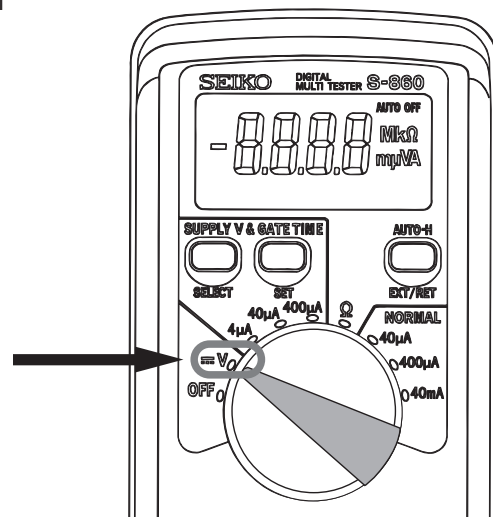

- 4) Expose the watch to the light of a fluorescent lamp (use the one with 15 to 20 watts) at a distance of 5 – 10 cm while connecting the probes to the watch.
- 5) Read the measurement and check if it exceeds 1.8 V.

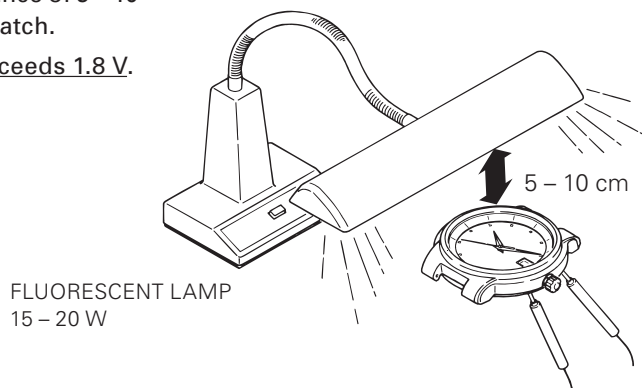

<How to check the solar power generation with the SOLAR CELL alone>

- 1) Set the SOLAR CELL to the HOLDING RING FOR DIAL.
- 2) Connect the tester as the below illustration.

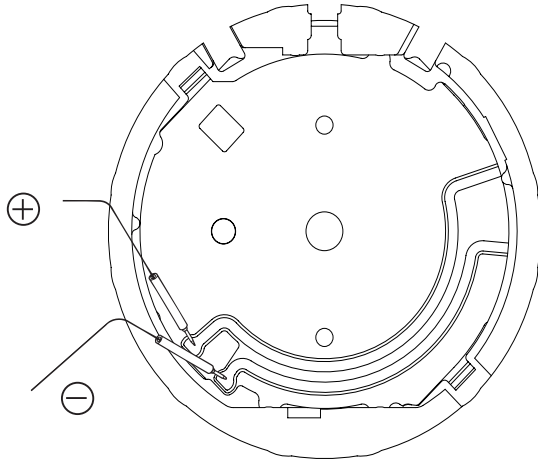

* When measuring the voltage using the SEIKO digital multi-tester (S-860), use the range of V.

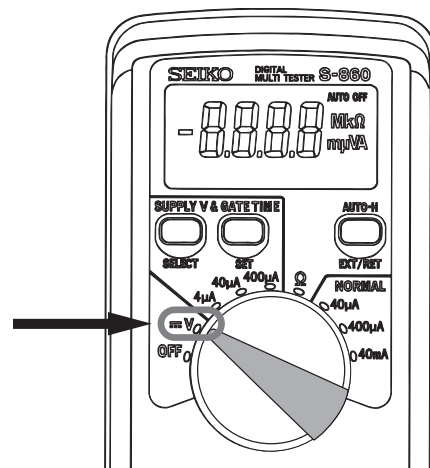

- 2) Expose the SOLAR CELL to the light of a fluorescent lamp (use the one with 15 to 20 watts) at a distance of 5 – 10 cm while connecting the probes to the solar cell unit (Fig. 7.)
- 3) Read the measurement and check if it exceeds 1.8 V.

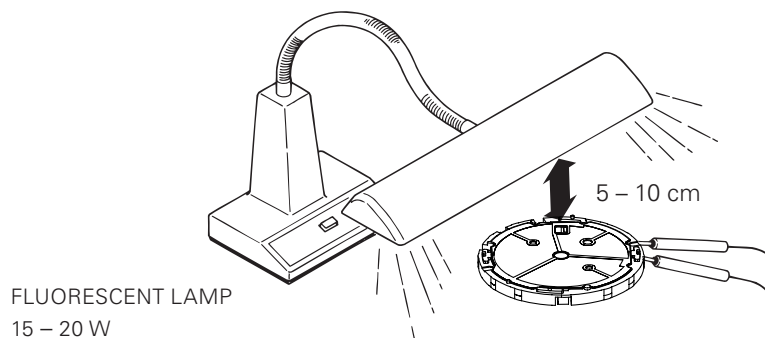

Note: In case the measurement of the voltage for the watch does not achieve the standard value but the measurement for the solar cell unit alone exceeds the standard value, a problem in the electrical conductivity between the solar cell unit and the movement is suspected. Inspect the electrical conductivity, especially at the CONTACT SPRING FOR SOLAR CELL, and check the solar power generation system again.

● CHECKING THE RECHARGING FUNCTION

In order to check the recharging function, measure the voltage of the rechargeable battery before and after recharging. If the voltage increases to a certain extent, it shows that the recharging function is working properly.

- 1) Connect the (-) probe and the (+) probe as illustrated.
- 2) Measure the voltage of the rechargeable battery before recharging.

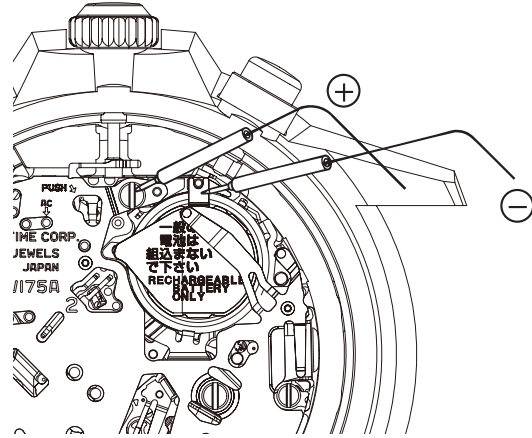

- 3) Recharge the watch by placing it at a distance of 5 – 10 cm under the fluorescent lamp of 15 to 20 watts for 30 minutes.

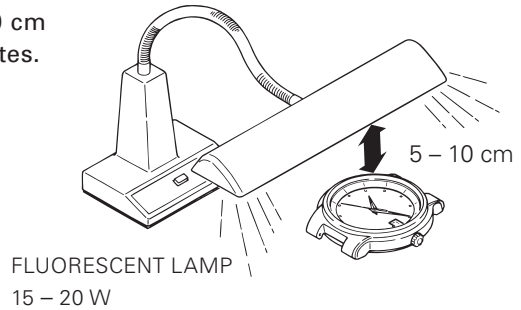

- 4) Measure the voltage again while keeping the watch exposed to the light.
- 5) Compare the difference of the voltage before and after recharging.

Refer to the table below for the criteria of the inspection.

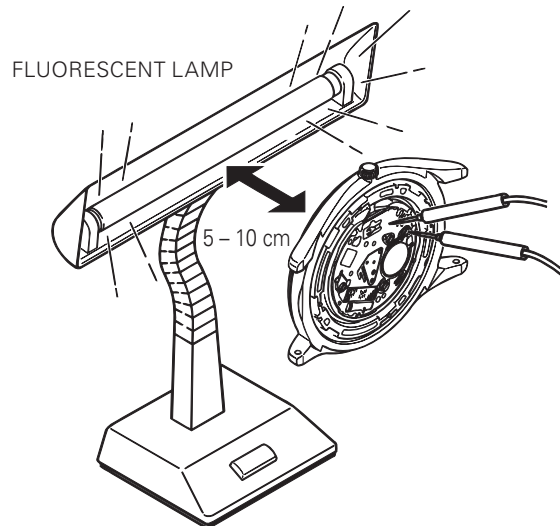

Table - criteria recharging function Cal. V175A

The voltage BEFORE recharging	Results after recharging and criteria for checking the function	
	Recharging function works fine	The battery needs to be inspected and replaced if necessary
0.50V - 1.00V	More than 1.10V	Less than 1.09V
1.01V - 1.30V	Increased by 0.03V or more	Not increased or increased but not more than by 0.03V

TROUBLESHOOTING

● IF THE WATCH DOES NOT MOVE PROPERLY AFTER RECHARGING.

Without recharging, the power stored in a solar watch begins to decline. The second hand starts moving at 2-second intervals indicating a diminished power reserve and eventually stops completely unless the watch is recharged.

The Cal. V17 series uses a CPU IC. In some circumstances, a CPU IC solar watch with a second hand moving at 2-second intervals may not return to the normal 1-second interval behavior even after the voltage is increased by recharging. Similarly, a completely stopped watch may not resume movement after the voltage is increased by recharging. This is not a defect but a characteristic of CPU IC watches. The watch can be restarted by resetting the IC. The instructions that follow explain how to reset the IC. In the event that the watch does not resume normal movement even after following these instructions, it is advisable to take your watch in to be serviced.

Troubleshooting flowchart

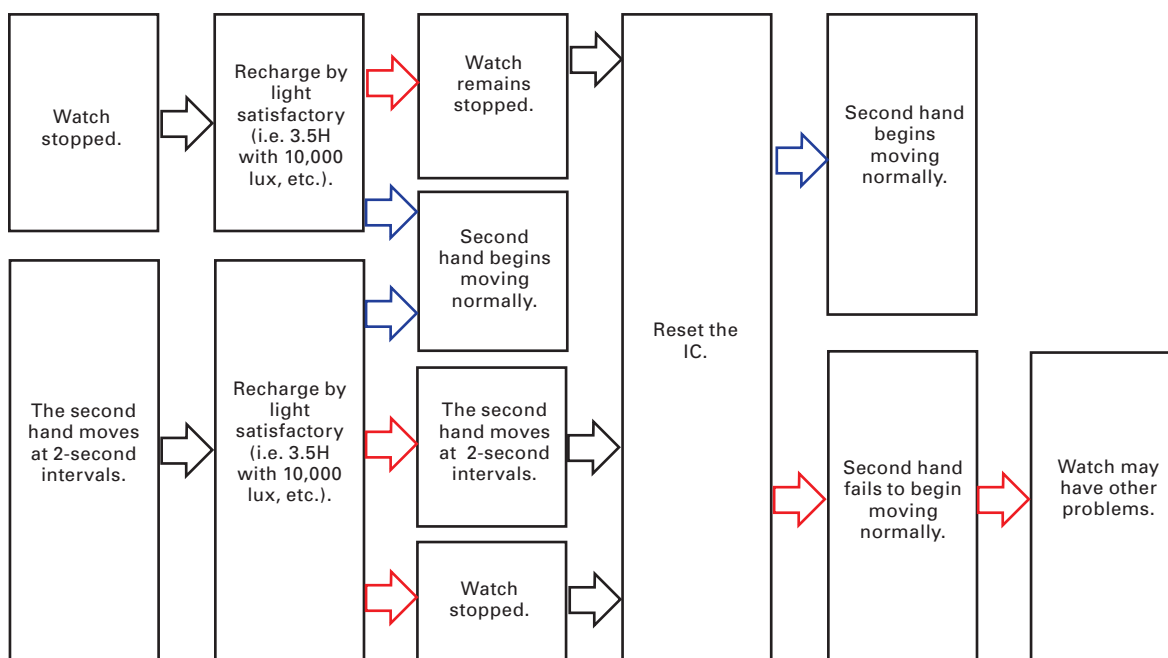

<How to reset the IC>

1. Pull out the crown to the second click.
 2. Keep pressing down button A and B for 3 seconds or longer.
 3. Push the crown back into the normal position and check if the small second hand moves as normal.
- It is also acceptable to reset the IC by short-circuit in touching AC pattern of the CIRCUIT BLOCK and metal part of rechargeable battery guard.

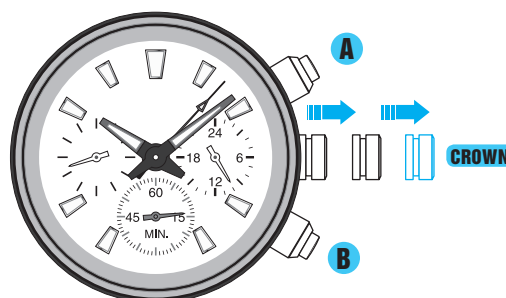

Resetting the IC will initialize the watch. Before starting to use the watch, it will be necessary to set the time and adjust the STOPWATCH hands to the "0" position. Refer to "SETTING THE TIME AND ADJUSTING THE STOPWATCH HAND POSITION" section in the Instruction booklet.